

Overview

HP sets the standard for performance and value in the enterprise with the Rack 10000 Series family. This enterprise-class rack cabinet system combines next-generation structural integrity and ease of use capabilities to deliver industry-leading performance. Ideal for onsite assembly of rack mounted ProLiant, Alpha, and Tandem servers, workstations, networking, and Storage products, the 10000 Rack Series of cabinets, complement and protect your customer's investment in technology. Specifically designed to ensure outstanding performance and seamless integration throughout the entire enterprise, the Rack 10000 could easily be the last family of racks that you ever have to buy.

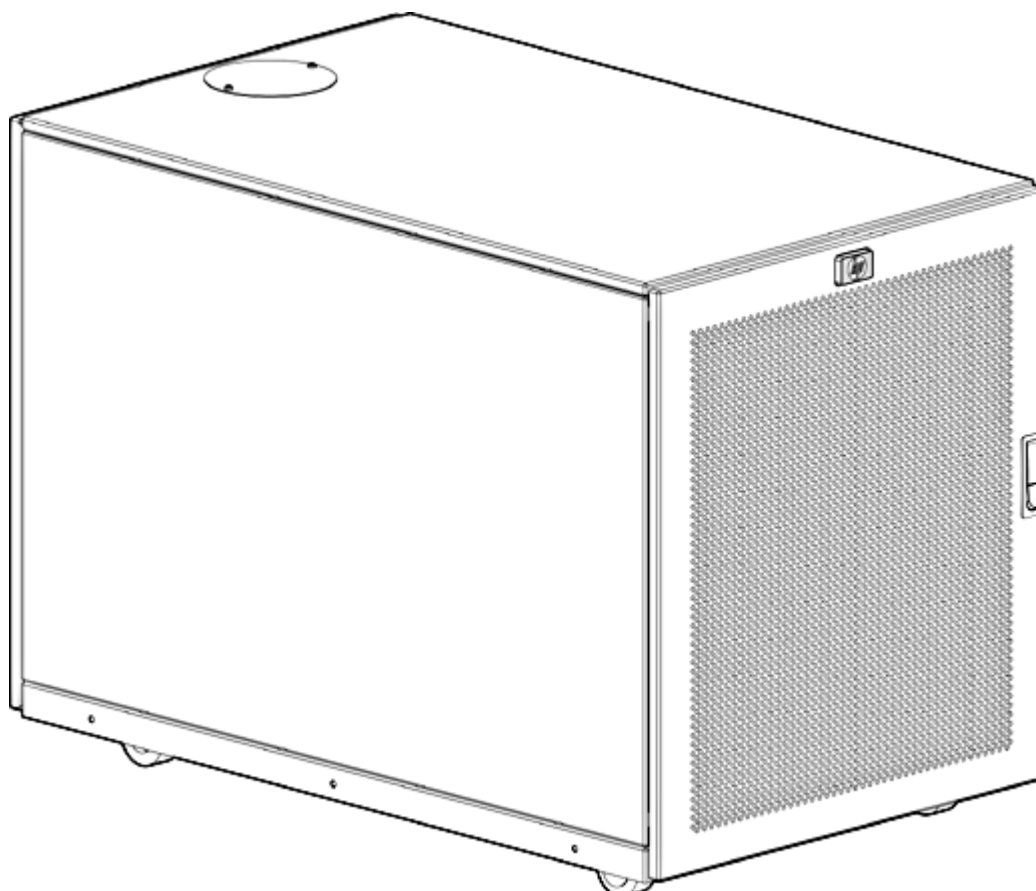

HP S101614, 14U Rack

What's New

- Updating supported options list.

At a Glance

- 14U height
- Thermal integrity
- Security provisions
- Shock pallet for factory CTO and dynamic loads
- Sidepanels included
- Heavy duty casters
- Powerful 3 year Warranty (3-0-0)

Overview

Models

HP S10614 (14U) Rack

292302-B22

NOTE: A rack with a shock pallet must be used when shipping racks with equipment installed.

Standard Features

Industry Standard Support

All products are 19 inch RETMA standard and will support select third-party equipment Extensive evaluation, and testing across all critical platforms

Key HP Infrastructure Rack components

Innovative Breakthroughs

- HP is the only IT rack provider to offer a complete line of options and accessories that are designed to support HP products.
 - HP's reputation for providing the highest quality products throughout the entire enterprise is based on our strategic partnerships, extensive product research, product development and product testing processes.
 - All rack sizes (including the S10614 rack are configurable at HP CTO (Configure to Order) facilities.
-

The HP Rack System

All HP rack-mountable products are designed to fit our industry-standard 19-inch wide racks. HP offers several racks to meet your system needs. Racks and rack-mountable components are typically described using "U" measurements. One "U" is 1.75" (44.45 mm) high.

This sturdy, industrial-strength rack series offers the following features:

- Universal - Accommodates all HP equipment (ProLiant, Alpha, Storage, UPS, PDU) in addition to select third party equipment
- Design - Perforated front and back doors which allows for high air flow and cooling up to 65% open; U marking front and sides of rails to ease component installation; increased cable management features

NOTE: Side Panels ship standard on the S10614 models.

Product Features

HP Rack 10000 Series Key Benefits (Universal Rack)

The HP Rack 10000 Series offers protection, price, performance and quality. The following are a few of the many benefits that come standard:

- **Unique Frame and Rail Design** - enables fast assembly, easy mounting and outstanding structural integrity. Equipment installation effort is dramatically reduced because the vertical mounting system was specifically designed to minimize the time required to install HP products, and can be used with many other non-HP products as well. U markings on the front and sides of rails make it easy to align parts when installing equipment. Cut outs in the rails also allows for cabling between racks.
- **Thermal Integrity** - Front to back natural convection cooling is greatly enhanced by the innovative multi-angled design of the front door. For additional heat removal, an optional roof mounted fan kit can be easily installed.*
- **Security Provisions** - Front and rear doors are lockable, which provides the necessary level of security to prevent unauthorized entry. Side panels are also lockable* allowing for your entire rack row to be secure.
- **Flexibility** - Outstanding cable management features make it easy to develop effective solutions and easy to maintain. Cable egresses in the top of the rack allow for ample room for routing cables outside of the rack. The split rear doors* give ample access to rack mounted equipment without blocking rack rows while the removable panel gives added flexibility for cable routing. Velcro straps are provided in the hardware bag for clean cable bundling within the rack.

* Except S10614. The side panels and roof are not removable and cannot be bayed. The S10614 features one back door (not split).

Low Total Cost of Ownership

Exclusive product options and accessories that optimize rack space utilization

- 0U and 1U mounting kits for options such as the new Modular Power Distribution Units (mPDU)
- Cost-saving Server Console Switches (KVM) with multiple mounting options
- TFT7600 Rackmount Keyboard and Monitor
- Highest levels of system management, performance, construction and compatibility

Investment Protection

- Investment security across all mainstream ProLiant server and storage products.
- Well-designed and crafted options provide unlimited flexibility in growing or adapting the 10000 series of rack cabinets to specific requirements and needs.
- Advanced product integration and quality provides high system reliability

Simplified Management

- Unique frame and rail design minimizes time necessary to install products in rack cabinet
- Product selection:
 - 47U @ 2.3 M
 - 42U @ 2.0 M
 - 36U @ 1.7 M
 - 22U @ 1.1 M
 - 14U @ 0.7 M
- All mainstream ProLiant server and storage products are easily managed with our seamless enterprise integration process

Industry-leading Breakthroughs

- Exclusive 42U in a two-meter rack cabinet height for easy door clearance
- The only company to provide a complete line of options and accessories that are designed to support HP products
- Special 14U rack designed specifically for remote site deployments.
- 2000 lb dynamic load capacity for the S10642



Service and Support, HP Care Pack, and Warranty Information

Warranty

Three year warranty, parts only (3-0-0).

NOTE: Certain restrictions and exclusions apply. Consult the HP Customer Support Center for details.

HP Care Pack Services HP Care Pack services include coverage for the HP branded hardware options qualified for the server and purchased at the same time or afterward that are internal to the enclosure. This also includes the 22" and smaller external monitors and tower UPS options up to 3kVA. These items will be covered at the same service level and for the same coverage period as the server. Coverage of UPS Battery is not included, and standard warranty terms & conditions apply. For servers or storage systems installed within a rack, service also covers all HP qualified rack options installed within the same rack.

- HP Services
 - To help streamline implementation and enhance ongoing support of rack solution, HP provides cost-effective service options with resources and specialized expertise to complement customers in-house capabilities.
- Installation and Startup services
 - Take advantage of complete installation and implementation support-including global rollout capabilities-to get rack solutions up-and-running rapidly, with minimal business disruption.
- Rack Option Hardware Support
 - Cover rack options with a single convenient service package. HP Care Pack Services for rack-mounted ProLiant DL servers and storage products provide support for all HP-branded rack hardware options that are qualified for inclusion with the server at the time of or after purchase. In addition, 22-inch and smaller external monitors, tower units, and UPS options up to 3KVA are covered at the same service level and for the same period as the server at not additional cost. Also covered are any additional HP-qualified rack options installed within the same rack.

HP Care Pack Services help increase uptime and productivity with rapid response on a 24x7 or 13x5 basis. Both options feature same-day, 4-hour onsite assistance when service issues cannot be resolved remotely. And both help enhance the return on server investment with proven HP Services expertise and consistent support levels across geographically dispersed sites.

NOTE: To learn more, please visit:

<http://www.hp.com/services/proliantservices>

<http://www.hp.com/services/bladesystems-services>

Related Options

Several options allow for quick and easy expansion of the HP Rack 10000 Series racks to create a custom solution.

NOTE: This is only a sampling of the many HP Rack options available. See the HP rack products Web site for more complete information at <http://www.hp.com/products/rackoptions>. Contact your nearest HP Authorized Reseller or Service Provider for information about ordering HP parts. In the United States, HP can make arrangements to have your rack system installed by qualified Guaranteed Service Providers. This installation service covers the entire hardware installation sequence, from unpacking the components to routing cabling and running a test of the system.

HP Airflow Optimization HP 10000 Series Rack Airflow Optimization Kit AF090A

NOTE: The Airflow Optimization kit is designed to prevent hot and cold air from mixing thus optimizing the temperature at which the chilled air enters the racked servers.

NOTE: When configuring racks through Factory Express, a Rack Optimization kit will automatically ship with the rack. This kit is recommended for all other rack configurations also.

HP Rack Light Kit HP Light Kit for 10000 Series Rack 361589-B21

NOTE: Supports HP Rack 10000 Series and HP Rack 10000 G2 series. This light kit is mounted on the rack roof and used to provide light to the rear section of the rack.

Rack Coupling Kit 10000 Rack Coupling Kit 248929-B21

NOTE: Supported by both the Rack 10000 and Rack 10000 G2 series. Supports 24 in and 600 mm floor tile spacing. The kit is used to join two or more 10000 series racks of the same height together in minutes to create a multi-bay configuration.

Offset Baying Kit HP 9000 to 10000 Rack Offset Baying Kit 248931-B21

NOTE: This kit can be used to connect 9000 and 10000 series racks of the same U height together. Kit contents include hardware for connecting racks and a panel to cover the 100mm gap at the rear of the two racks.

Grounding Kit HP 10000 G2 Series Rack Grounding Kit AF074A

NOTE: Supported by the Rack 10000 and Rack 10000 G2 series.

NOTE: 0D1 will appear after the above selected part numbers on yours sales order if factory integration is indicated.

HP Cable Management Kits Compaq Cable Management D Rings 168233-B21

NOTE: This kit consists of 10 "D" rings that can be used in addition to the rings that ship standard in the 10000 series and 10000 G2 series racks for cable management.

HP Rack Cable Management Velcro Clips 379820-B21

NOTE: 50 pack.

HP Rack Cable Management Kit AF099A

NOTE: This kit provides an easy way to organize and route cables within HP Racks. Cable clips, cable rings, and 1U and 2U access panels are included.

NOTE: 0D1 will appear after the above selected part numbers on yours sales order if factory integration is indicated.

Related Options

HP Locking Drawer	<p>HP 2U Universal Locking Drawer 361591-B21</p> <p>NOTE: This product mounts on HP 10000 Series and HP Rack 10000 G2 series racks with sliding rails and is used to store CD's, Instruction manuals, tools, and any other item that is frequently used at the rack. Drawer includes lock.</p> <p>NOTE: 0D1 will appear after the above selected part numbers on yours sales order if factory integration is indicated.</p>
--------------------------	--

HP Rack Cable Trays	<p>HP 600 Wide Rack Top Cable Tray 383982-B21</p> <p>HP 800 Wide Rack Top Cable Tray 383983-B21</p> <p>HP Rack Top Cable Mgmt Transfer Tray 383984-B21</p> <p>NOTE: The HP Rack Top Cable Mgmt Transfer Tray allows for cabling trays to be connected even across different aisles in the datacenter.</p> <p>NOTE: These kits mount on the top of the 9000 and 10000 Series rack (except the S10614 rack). Kit color is graphite.</p>
----------------------------	--

Rack Cooling	<p>HP 10000 Rack Roof Mount Fan (110V) Kit 257413-B21</p> <p>HP 10000 Rack Roof Mount Fan (220V) Kit 257414-B21</p> <p>NOTE: 0D1 will appear after the above selected part numbers on yours sales order if factory integration is indicated.</p>
---------------------	---

Keyboard and Monitors	<p>HP TFT7600 G2 KVM Console Rackmount Keyboard US Monitor AZ870A</p> <p>HP TFT7600 G2 KVM Console Rackmount Keyboard UK Monitor AZ871A</p> <p>HP TFT7600 G2 KVM Console Rackmount Keyboard DE Monitor AZ872A</p> <p>HP TFT7600 G2 KVM Console Rackmount Keyboard FR Monitor AZ873A</p> <p>HP TFT7600 G2 KVM Console Rackmount Keyboard IT Monitor AZ874A</p> <p>HP TFT7600 G2 KVM Console Rackmount Keyboard ES Monitor AZ875A</p> <p>HP TFT7600 G2 KVM Console Rackmount Keyboard DK Monitor AZ876A</p> <p>HP TFT7600 G2 KVM Console Rackmount Keyboard NO Monitor AZ877A</p> <p>HP TFT7600 G2 KVM Console Rackmount Keyboard SE/FI Monitor AZ878A</p> <p>HP TFT7600 G2 KVM Console Rackmount Keyboard CH Monitor AZ879A</p> <p>HP TFT7600 G2 KVM Console Rackmount Keyboard PT Monitor AZ880A</p> <p>HP TFT7600 G2 KVM Console Rackmount Keyboard BE Monitor AZ881A</p> <p>HP TFT7600 G2 KVM Console Rackmount Keyboard JP Monitor AZ882A</p> <p>HP TFT7600 G2 KVM Console Rackmount Keyboard RU Monitor AZ883A</p> <p>HP TFT7600 G2 KVM Console Rackmount Keyboard Intl Monitor AZ884A</p> <p>HP TFT7600 G2 KVM Console Rackmount Keyboard US TAA Monitor AZ885A</p> <p>NOTE: Please see the QuickSpecs for additional information: http://h18000.www1.hp.com/products/quickspecs/13731_div/13731_div.html (Worldwide)</p>
------------------------------	--

Related Options

Universal 1U Filler Panels

HP 1U 10-pack Carbon Universal Filler Panel	AF070A
HP 1U 100-pack Carbon Universal Filler Panel	AF071A

NOTE: The blanking panels are made from high grade molded plastic, and are designed to be installed without tools. The use of blanking panels is recommended to ensure proper airflow.

NOTE: 0D1 will appear after the above selected part numbers on yours sales order if factory integration is indicated.

HP Modular Power Distribution Units (Zero-U/1U Modular PDUs)

North America, Japan, and South America (Except Argentina and Chile)

100 - 127v 1Ø

HP 2.8kVA 24A Low Voltage NA/JP Modular Power Distribution Unit	252663-D71
---	------------

200 - 240v 1Ø

HP 3.6kVA 16A High Voltage INTL Modular Power Distribution Unit	252663-B24
HP 4.9kVA 24A High Voltage NA/JP Modular Power Distribution Unit	252663-D72
HP 8.3kVA 40A High Voltage INTL Modular Power Distribution Unit	252663-B21
HP 8.3kVA 40A High Voltage NA/JP Modular Power Distribution Unit	252663-D73
HP 8.3kVA 40A High Voltage NA/JP Core Modular Power Distribution Unit	252663-D75
HP 4.9kVA 24A High Voltage NA/JP Core Modular Power Distribution Unit	252663-D74

200 - 240v 3Ø

HP 8.6kVA 24A Three Phase NA/JP Modular Power Distribution Unit	AF512A
HP 14.4kVA 40A Three Phase NA/JP Modular Power Distribution Unit	AF519A
HP 17.3kVA 48A Three Phase NA/JP Modular Power Distribution Unit	AF511A

International (Including Argentina and Chile)

200 - 240v 1Ø

HP 7.3kVA 32A High Voltage INTL Modular Power Distribution Unit	252663-B31
HP 9.2kVA 40A High Voltage INTL Modular Power Distribution Unit	252663-B32
HP 9.2kVA 40A High Voltage INTL Core Modular Power Distribution Unit	252663-B34
HP 7.3kVA 32A High Voltage INTL Core Modular Power Distribution Unit	252663-B33

380 - 415v 3Ø

HP 11kVA 16A Three Phase INTL Modular Power Distribution Unit	AF513A
HP 22kVA 32A Three Phase INTL Core Modular Power Distribution Unit	AF518A

NOTE: Please see the QuickSpecs for additional information:

http://h18000.www1.hp.com/products/quickspecs/11041_div/11041_div.html
(Worldwide)

Related Options

HP Monitored Power Distribution Unit	HP Monitored Power Distribution Unit - Full Rack Version	
	HP 17.3kVA 24A Dual Three Phase NA/JP Monitored Power Distribution Unit	AF503A
	HP 8.6kVA 24A Single Input Three Phase NA/JP Monitored Power Distribution Unit	AF504A
	HP 16.6kVA 40A Dual Input Single Phase NA/JP Monitored Power Distribution Unit	AF505A
	HP 8.3kVA 40A Single Input Single Phase NA/JP Monitored Power Distribution Unit	AF506A
	HP 22.1kVA 16A Dual Input Three Phase INTL Monitored Power Distribution Unit	AF507A
	HP 11kVA 16A Single Input Three Phase INTL Monitored Power Distribution Unit	AF508A
	HP 14.7kVA 32A Dual Input Single Phase INTL Monitored Power Distribution Unit	AF509A
	HP 7.3kVA 32A Single Input Single Phase INTL Monitored Power Distribution Unit	AF510A
	HP Monitored Power Distribution Unit - Half Rack Version	
	HP 4.9kVA 24A Single Input Single Phase NA/JP Monitored Power Distribution Unit	AF914A
	HP 7.3kVA 32A Single Input Three Phase INTL Intelligent Modular Power Distribution Unit	AF536A
	HP 17.3kVA 48A Single Input Three Phase NA/JP Monitored Power Distribution Unit	AF916A
	HP 7.3kVA 32A Single Input Single Phase INTL Monitored Power Distribution Unit	AF915A
HP 22kVA 32A Single Input Three Phase INTL Monitored Power Distribution Unit	AF917A	
NOTE: Please see the QuickSpecs for additional information: http://h18000.www1.hp.com/products/quickspecs/12118_div/12118_div.html (Worldwide)		

HP Intelligent Power Distribution Units (iPDU)	HP 4.9kVA 24A Single Phase NA/JP Core Intelligent Modular Power Distribution Unit	AF520A
	HP 8.3kVA 40A Single Phase NA/JP Core Intelligent Modular Power Distribution Unit	AF521A
	HP 8.6kVA 24A Three Phase NA/JP Core Intelligent Modular Power Distribution Unit	AF522A
	HP 14.4kVA 40A Three Phase NA/JP Intelligent Modular Power Distribution Unit	AF533A
	HP 17.3kVA 48A Three Phase NA/JP Core Intelligent Modular Power Distribution Unit	AF523A
	HP 11.4kVA 16A 415V Three Phase L22-20 NA Core Intelligent Power Distribution Unit	AF900A
	HP 17.3kVA 24A 415V Three Phase L22-30 NA Core Intelligent Power Distribution Unit	AF902
	HP 17.3kVA 24A 415V Three Phase IEC309 NA Core Intelligent Power Distribution Unit	AF901A
	HP 7.3kVA 32A Single Phase INTL Core Intelligent Modular Power Distribution Unit	AF525A
	HP 11kVA 16A Three Phase INTL Core Intelligent Modular Power Distribution Unit	AF526A

Related Options

HP 22kVA 32A Three Phase INTL Core Intelligent Modular Power Distribution Unit	AF527A
HP 17.3kVA 48A 208V Three Phase 12 Outlet Core NA/JP Intelligent Power Distribution Unit	AF535A
HP 17.3kVA 24A 415V Three Phase 12 Outlet Core NA/JP Intelligent Power Distribution Unit	AF537A
HP 22kVA 32A 400V Three Phase 12 Outlet Core INTL Intelligent Power Distribution Unit	AF538A

IPDU Kits with Standard Extension Bars

HP 4.9kVA 24A Single Phase NA/JP Intelligent Modular Power Distribution Kit	AF531A
HP 8.6kVA 24A Three Phase NA/JP Intelligent Modular Power Distribution Kit	AF532A
HP 7.3kVA 32A Single Phase INTL Intelligent Modular Power Distribution Kit	AF534A

NOTE: For additional information on HP Intelligent PDUs please see: www.hp.com/go/ipdu

HP R1500 G3 Uninterruptible Power Supply (UPS)	HP R1.5kVA G3 1U NA Uninterruptible Power System	AF469A
	HP R1.5kVA G3 1U JP/TW Uninterruptible Power System	AF470A
	HP R1.5kVA G3 1U INTL Uninterruptible Power System	AF471A

NOTE: Please see the QuickSpecs for additional information: http://h18000.www1.hp.com/products/quickspecs/14059_div/14059_div.html (Worldwide)

HP R/T3000 G2 Uninterruptible Power System (UPS)	HP R/T3000 G2 2U L530 Low Voltage NA/JP Uninterruptible Power System	AF466A
	HP R/T3000 G2 2U L620 High Voltage NA/JP Uninterruptible Power System	AF467A
	HP R/T3000 G2 2U Detachable Cord High Voltage INTL Uninterruptible Power System	AF468A

NOTE: Please see the QuickSpecs for additional information: http://h18000.www1.hp.com/products/quickspecs/13417_div/13417_div.html (Worldwide)

R5000 Uninterruptible Power System (UPS)	HP R5KVA 3U IEC309-32A High Voltage INTL Uninterruptible Power System	AF461A
	HP R5KVA 3U L630 High Voltage NA/JP Uninterruptible Power System	AF460A

NOTE: Please see the QuickSpecs for additional information: http://h18000.www1.hp.com/products/quickspecs/14109_div/14109_div.html (Worldwide)

R7000 Uninterruptible Power System (UPS)	HP R7KVA 4U 50A High Voltage NA/JP Uninterruptible Power System	AF462A
	HP R7KVA 4U IEC-32A High Voltage INTL Uninterruptible Power System	AF463A

NOTE: Please see the QuickSpecs for additional information: http://h18000.www1.hp.com/products/quickspecs/14110_div/14110_div.html (Worldwide)

Related Options

HP Rack-Mountable R5500 UPS	HP R5500 6000VA INTL 3U Rackmount Uninterruptible Power System	AF416A
	HP R5500 5000kVA NA/JP 3U Rackmount Uninterruptible Power System	AF426A
NOTE: Please see the QuickSpecs for additional information: http://h18000.www1.hp.com/products/quickspecs/11817_div/11817_div.html (Worldwide)		
HP Parallel 3 Phase Uninterruptible Power Systems (UPS RP36000/3)	HP RP36000/3 36000VA Three Phase NA Uninterruptible Power System	AF438A
	HP RP36000/3 36000VA Three Phase INTL Uninterruptible Power System	AF439A
NOTE: Please see the QuickSpecs for additional information: http://h18000.www1.hp.com/products/quickspecs/12856_div/12856_div.html (Worldwide)		
HP Parallel 3 Phase Uninterruptible Power Systems (UPS RP36000/3)	HP R8000/3	
	HP R8000/3 8000kVA Three Phase NA 6U Rackmount Uninterruptible Power System	AF431A
	HP R8000/3 8000kVA Three Phase INTL 6U Rackmount Uninterruptible Power System	AF432A
	HP R12000/3	
	HP R12000/3 12000VA Three Phase NA 6U Rackmount Uninterruptible Power System	AF429A
	HP R12000/3 12000VA Three Phase INTL 6U Rackmount Uninterruptible Power System	AF430A
NOTE: Please see the QuickSpecs for additional information: http://h18000.www1.hp.com/products/quickspecs/12857_div/12857_div.html (Worldwide)		
HP 1x4 USB/PS2 KVM Switch	HP 1x4 USB/PS2 KVM Console Switch	AF611A
	HP 1x4 KVM Console 6ft PS2 Cable	AF612A
	HP 1x4 KVM Console 6ft USB Cable	AF613A
NOTE: USB cable required for supporting USB peripherals. NOTE: Please see the QuickSpecs for additional information: http://h18000.www1.hp.com/products/quickspecs/12662_div/12662_div.html (Worldwide)		

Related Options

HP KVM Switch Options

HP Server Console 0x2x8 Port Analog Switch	AF616A
HP Server Console 0x2x16 Port Analog Switch	AF617A

NOTE: Please see the QuickSpecs for additional information:
http://h18000.www1.hp.com/products/quickspecs/11834_div/11834_div.html
 (Worldwide)

Interface Adapters

HP KVM CAT5 1-pack PS/2 Interface Adapter	262588-B21
HP KVM CAT5 8-pack PS/2 Interface Adapter	262587-B21
HP KVM CAT5 1-pack USB Interface Adapter	336047-B21
HP KVM CAT5 1-pack Serial Interface Adapter	373035-B21

NOTE: Please see the QuickSpecs for additional information:
http://h18000.www1.hp.com/products/quickspecs/13474_div/13474_div.html
 (Worldwide)

NOTE: Cat5e cables are required to connect Interface Adapters to Console Switches. Cat5e cables can be found at the following URL:
<http://www.hp.com/go/kvm>.

NOTE: For additional information regarding KVM switches, Serial Console servers, rack mount monitors, keyboards and all related options please see the following URL: <http://www.hp.com/go/kvm>.

HP Serial Console Server Options

HP 16 Port Serial Console Server	AF101A
HP 48 Port Serial Console Server	AF102A
HP CAT5 RJ45-DB9 DCE Female 1 Pack Serial Adapter	AF103A
HP CAT5 RJ45-DB9 DCE Female 8 Pack Serial Adapter	AF110A

NOTE: Please see the QuickSpecs for additional information:
http://h18000.www1.hp.com/products/quickspecs/12118_div/12118_div.html
 (Worldwide)

NOTE: Cat5e cables are required to connect Interface Adapters to Console Switches. Cat5e cables can be found at the following URL:
<http://www.hp.com/go/kvm>.

HP Care Pack Services HP Install Rack and Rack Options Service	U2871E
---	--------

Technical Specifications

S10614 Rack Physical Characteristics

Dimensions (HxDxW)	Total Cabinet Area	28.5 x 39.69 x 23.6 in (72.4 x 100 x 60 cm)
	Shipping (with packaging materials)	34 x 44x 30.5 in (86.36 x 111.82 x 77.5 cm)
Weight	Operating	135 lb (61 kg)
	Shipping	190 lb (86.18 kg)
Load	Static	600 lb (270 kg)
	Dynamic	500 lb (227 kg)
Color	Doors	Graphite Metallic
	Frame	Carbon

Environment-friendly Products and Approach	End-of-life Management and Recycling	Hewlett-Packard offers end-of-life HP product return, trade-in, and recycling programs in many geographic areas. For trade-in information, please go to: http://www.hp.com/go/green . To recycle your product, please go to: http://www.hp.com/go/green or contact your nearest HP sales office. Products returned to HP will be recycled, recovered or disposed of in a responsible manner.
---	---	--

The EU WEEE directive (2002/95/EC) requires manufacturers to provide treatment information for each product type for use by treatment facilities. This information (product disassembly instructions) is posted on the Hewlett Packard web site at: <http://www.hp.com/go/green>. These instructions may be used by recyclers and other WEEE treatment facilities as well as HP OEM customers who integrate and re-sell HP equipment.

© Copyright 2012 Hewlett-Packard Development Company, L.P.

The information contained herein is subject to change without notice.

The only warranties for HP products and services are set forth in the express warranty statements accompanying such products and services. Nothing herein should be construed as constituting an additional warranty. HP shall not be liable for technical or editorial errors or omissions contained herein.